



## Characteristics



- Energy saving heat pump air curtains: Up to 70% reduction in costs and CO<sub>2</sub> emissions (heating mode).
- Compact and low profile recessed air curtain with full grille view.
- Self-supporting casing construction made of galvanized steel plate, ready to be installed recessed in a false ceiling.
- Inlet grille (free of maintenance) made with aluminium profiles and blow-out nozzle, integrated in a single white frame colour RAL 9016. Other colours are available on request.
- EC Double-inlet centrifugal fans driven by an external rotor motor and low noise level, with very low consumption efficiency fans.
- Includes direct expansion coil with sensors. Optional condensate water pump.
- CS-5DX-NE Plug&Play control with 5 speeds and telephone cable 7m included.
- Requires TOSHIBA DX Interface KIT adapted for air curtain and programmable control, please consult.
- Ready to connect to TOSHIBA Inverter outdoor heat pump unit (R410A) with expansion valve, not included, the customer should purchase it.

## Specifications

Model	Airflow m <sup>3</sup> /h	Outdoor Unit (*)		Power Fan	Current Fan	Noise Level	Weight
		230Vx1	400Vx3	230V-50Hz kW	230V-50Hz A	(5 m) dB(A)	
RDAM ECM 1500 DX11-TO	2460	RAV-SM1104ATP-E	RAV-SP1104AT8-E	0,198	1,71	57	74
RDAM ECM 2000 DX16-TO	3280	RAV-SM1603AT-E	RAV-SP1604AT8-E	0,264	2,28	58	95
RDAM ECM 2000 DX19-TO	3280	-	RAV-SM2244AT8-E	0,264	2,28	58	95
RDAM ECM 2500 DX21-TO	4100	-	RAV-SM2244AT8-E	0,330	2,85	59	106
RDAM ECM 2500 DX24-TO	4100	-	RAV-SM2804AT8-E	0,330	2,85	59	106
RDAM ECG 1000 DX10-TO	2190	RAV-SM1104ATP-E	RAV-SP1104AT8-E	0,225	1,95	61	55
RDAM ECG 1500 DX13-TO	2920	RAV SM1404ATP-E	RAV SP1404AT8-E	0,300	2,60	62	80
RDAM ECG 1500 DX15-TO	2920	RAV-SM1603AT-E	RAV-SP1604AT8-E	0,300	2,60	62	80
RDAM ECG 2000 DX22-TO	4380	-	RAV-SM2244AT8-E	0,450	3,90	63	105
RDAM ECG 2000 DX24-TO	4380	-	RAV-SM2804AT8-E	0,450	3,90	63	105
RDAM ECG 2500 DX22-TO	5110	-	RAV-SM2244AT8-E	0,525	4,55	64	114
RDAM ECG 2500 DX27-TO	5110	-	RAV-SM2804AT8-E	0,525	4,55	64	114

(\*) Includes direct expansion valve.

TOSHIBA Inverter Outdoor Units	Heating Capacity kW	Heating Power kW	SCOP or COP	Cooling Capacity kW	Cooling Power kW	SEER or EER	Power Supply	Pipes		Pipes Minimum Length m	Pipes Maximum Length m	Pipes Maximum Height m
								Gas	Liquid			
								inch	inch			
RAV-SM1104ATP-E	11,2	2,93	3,54	10,0	3,11	5,58	230Vx1	5/8	3/8	5	50	30
RAV-SP1104AT8-E	11,2	2,42	4,28	10,0	2,37	6,57	400Vx3	5/8	3/8	3	75	30
RAV SM1404ATP-E	14,0	3,80	3,68	12,0	3,74	3,21	230Vx1	5/8	3/8	5	50	30
RAV SP1404AT8-E	14,0	3,42	4,09	12,5	3,46	3,61	400Vx3	5/8	3/8	3	75	30
RAV-SM1603AT-E	16,0	4,43	3,61	14,0	4,49	3,12	230Vx1	5/8	3/8	5	50	30
RAV-SP1604AT8-E	16,0	4,30	3,72	14,0	4,49	3,12	400Vx3	5/8	3/8	3	75	30
RAV-SM2244AT8-E	22,4	6,49	3,45	20,0	7,20	2,78	400Vx3	1"1/8	1/2"	7,5	70	30
RAV-SM2804AT8-E	27,0	8,15	3,31	23,0	8,75	2,63	400Vx3	1"1/8	1/2"	7,5	70	30

Energy efficiency: SCOP/SEER seasonal ≤12kW, COP/EER >12kW.

Outdoor unit capacities depending on standard conditions: heating 20°CDB indoor / 7°CDB and 6°CWB outdoor, cooling 27°CDB and 19°CWB indoor / 35°CDB outdoor.

When adverse weather conditions, the outdoor unit capacity can decrease. It is recommendable to oversize the units.



## Characteristics



- Energy saving heat pump air curtains: Up to 70% reduction in costs and CO<sub>2</sub> emissions (heating mode).
- Compact and low profile recessed air curtain with full grille view.
- Self-supporting casing construction made of galvanized steel plate, ready to be installed recessed in a false ceiling.
- Inlet grille (free of maintenance) made with aluminium profiles and blow-out nozzle, integrated in a single white frame colour RAL 9016. Other colours are available on request.
- EC Double-inlet centrifugal fans driven by an external rotor motor and low noise level, with very low consumption efficiency fans.
- Includes direct expansion coil with sensors. Optional condensate water pump.
- CS-5DX-NE Plug&Play control with 5 speeds and telephone cable 7m included.
- Requires TOSHIBA VRF Interface KIT adapted for air curtain, programmable control and expansion valve, please consult.
- Ready to connect to TOSHIBA VRF outdoor heat pump unit (R410A), not included, the customer should purchase it.

## Specifications

Model	Airflow m <sup>3</sup> /h	Toshiba Direct Expansion Valve	Power Fan 230V-50Hz kW	Current Fan 230V-50Hz A	Noise Level (5 m) dB(A)	Weight kg
RDAM ECM 1500 VRF12-TO	2460	MMDXV140	0,198	1,71	57	74
RDAM ECM 2000 VRF16-TO	3280	MMDXV140	0,264	2,28	58	95
RDAM ECM 2000 VRF19-TO	3280	MMDXV280	0,264	2,28	58	95
RDAM ECM 2500 VRF21-TO	4100	MMDXV280	0,330	2,85	59	106
RDAM ECM 2500 VRF24-TO	4100	MMDXV280	0,330	2,85	59	106
RDAM ECG 1000 VRF10-TO	2190	MMDXV140	0,225	1,95	61	55
RDAM ECG 1500 VRF13-TO	2920	MMDXV140	0,300	2,60	62	80
RDAM ECG 1500 VRF15-TO	2920	MMDXV140	0,300	2,60	62	80
RDAM ECG 2000 VRF20-TO	4380	MMDXV280	0,450	3,90	63	105
RDAM ECG 2000 VRF24-TO	4380	MMDXV280	0,450	3,90	63	105
RDAM ECG 2500 VRF25-TO	5110	MMDXV280	0,525	4,55	64	114
RDAM ECG 2500 VRF29-TO	5110	MMDXV280	0,525	4,55	64	114

### TOSHIBA VRF Outdoor Units

Mini, Mini SMMSe, SMMS (Heat Pump)

SHRMe (Heat Recovery)



When adverse weather conditions, the outdoor unit capacity can decrease. It is recommendable to oversize the units.



**Dimensions**

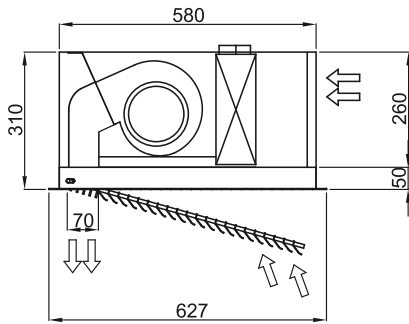
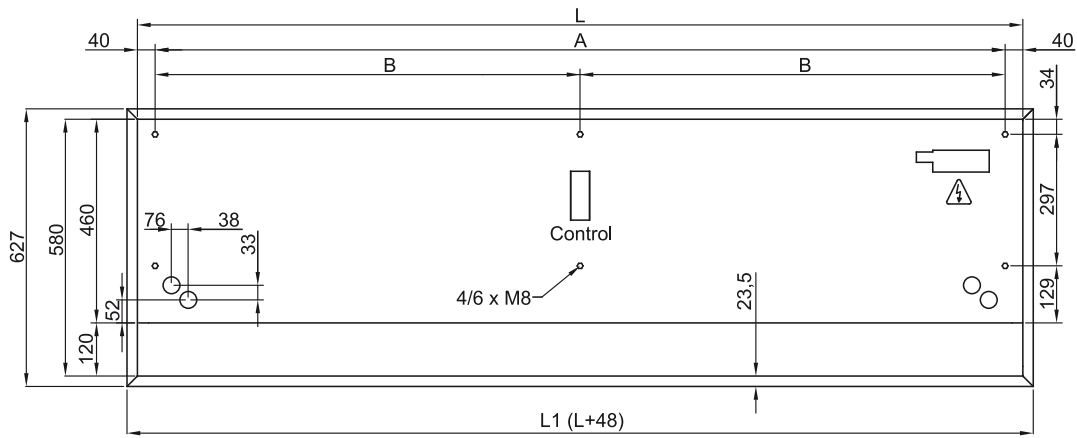

	L	L1	A	B
RDAM 1000	1000	1048	920	-
RDAM 1500	1500	1548	1420	710
RDAM 2000	2000	2048	1920	960
RDAM 2500	2500	2548	2420	1210

**Finishes and details**



Detail of exposed inlet grille

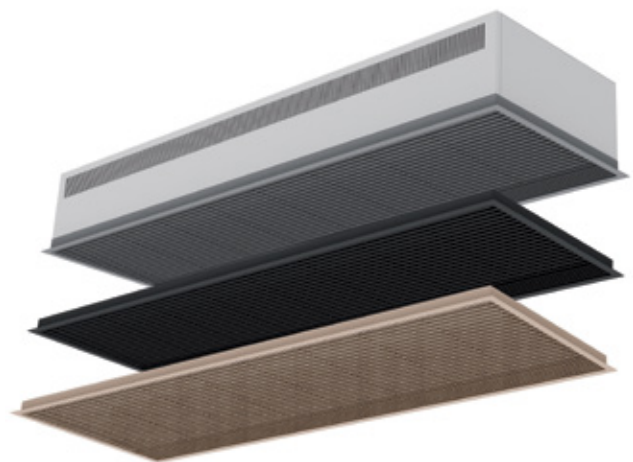

Customizable inlet grille in RAL color optionally