



Characteristics



- Energy saving heat pump air curtains: Up to 70% reduction in costs and CO₂ emissions (heating mode).
- Compact and low profile recessed air curtain with full grille view.
- Self-supporting casing construction made of galvanized steel plate, ready to be installed recessed in a false ceiling.
- Inlet grille (free of maintenance) made with aluminium profiles and blow-out nozzle, integrated in a single white frame colour RAL 9016. Other colours are available on request.
- EC Double-inlet centrifugal fans driven by an external rotor motor and low noise level, with very low consumption efficient fans.
- Includes direct expansion coil with sensors. Optional condensate water pump.
- CS-5DX-NE Plug&Play control with 5 speeds and telephone cable 7m included.
- Requires MITSUBISHI ELECTRIC DX Interface KIT adapted for air curtain and programmable control, please consult.
- Ready to connect to MITSUBISHI ELECTRIC Standard and Power Inverter outdoor heat pump unit (R410A) with expansion valve, not included, the customer should purchase it.

Specifications

Model	Airflow m ³ /h	Outdoor Unit (*)		Power Fans 230V-50Hz kW	Current Fans 230V-50Hz A	Noise Level (5 m) dB(A)	Weight kg
		230Vx1	400Vx3				
RDAM ECM 1000 DX8-ME	1640	PUHZ-ZRP71VHA	-	0,132	1,14	56	50
RDAM ECM 1500 DX11-ME	2460	PUHZ-ZRP100VKA	PUHZ-ZRP100YKA	0,198	1,71	57	74
RDAM ECM 1500 DX13-ME	2460	PUHZ-ZRP125VKA	PUHZ-ZRP125YKA	0,198	1,71	57	74
RDAM ECM 2000 DX16-ME	3280	PUHZ-ZRP140VKA	PUHZ-ZRP140YKA	0,264	2,28	58	95
RDAM ECM 2500 DX22-ME	4100	-	PUHZ-ZRP200YKA	0,330	2,85	59	106
RDAM ECM 2500 DX24-ME	4100	-	PUHZ-ZRP250YKA	0,330	2,85	59	106
RDAM ECG 1000 DX10-ME	2190	PUHZ-ZRP100VKA	PUHZ-ZRP100YKA	0,225	1,95	61	55
RDAM ECG 1500 DX14-ME	2920	PUHZ-ZRP125VKA	PUHZ-ZRP125YKA	0,300	2,60	62	80
RDAM ECG 2000 DX22-ME	4380	-	PUHZ-ZRP200YKA	0,450	3,90	63	105
RDAM ECG 2000 DX24-ME	4380	-	PUHZ-ZRP250YKA	0,450	3,90	63	105
RDAM ECG 2500 DX27-ME	5110	-	PUHZ-ZRP250YKA	0,525	4,55	64	114

(*) Includes direct expansion valve.

MITSUBISHI Power Inverter (*) Outdoor Units	Heating Capacity kW	Heating Power kW	SCOP or COP	Cooling Capacity kW	Cooling Power kW	SEER or EER	Power Supply	Pipes		Pipes Minimum Length m	Pipes Maximum Length m	Pipes Maximum Height m
								Gas	Liquid			
PUHZ-ZRP71VHA	8,0	2,03	3,90	7,1	2,01	5,60	230Vx1	5/8	3/8	-	50	30
PUHZ-ZRP100VKA	11,2	2,06	4,20	10,0	2,63	5,60	230Vx1	5/8	3/8	-	75	30
PUHZ-ZRP100YKA	11,2	2,06	4,20	10,0	2,63	5,50	400Vx3	5/8	3/8	-	75	30
PUHZ-ZRP125VKA	14,0	3,63	3,86	12,5	4,05	3,09	230Vx1	5/8	3/8	-	75	30
PUHZ-ZRP125YKA	14,0	3,63	3,86	12,5	4,05	3,09	400Vx3	5/8	3/8	-	75	30
PUHZ-ZRP140VKA	16,0	4,20	3,81	13,4	4,36	3,07	230Vx1	5/8	3/8	-	75	30
PUHZ-ZRP140YKA	16,0	4,20	3,81	13,4	4,36	3,07	400Vx3	5/8	3/8	-	75	30
PUHZ-ZRP200YKA	22,4	6,94	3,23	19,0	6,46	2,94	400Vx3	1	3/8	-	100	30
PUHZ-ZRP250YKA	27,0	8,94	3,75	22,0	8,31	2,65	400Vx3	1	1/2	-	100	30

(*) Also compatible with Standard Inverter outdoor units.

Energy efficiency: SCOP/SEER seasonal ≤12kW, COP/EER >12kW.

Outdoor unit capacities depending on standard conditions: heating 20°CDB indoor / 7°CDB and 6°CWB outdoor, cooling 27°CDB and 19°CWB indoor / 35°CDB outdoor.

When adverse weather conditions, the outdoor unit capacity can decrease. It is recommendable to oversize the units.



Characteristics



- Energy saving heat pump air curtains: Up to 70% reduction in costs and CO₂ emissions (heating mode).
- Compact and low profile recessed air curtain with full grille view.
- Self-supporting casing construction made of galvanized steel plate, ready to be installed recessed in a false ceiling.
- Inlet grille (free of maintenance) made with aluminium profiles and blow-out nozzle, integrated in a single white frame colour RAL 9016. Other colours are available on request.
- EC Double-inlet centrifugal fans driven by an external rotor motor and low noise level, with very low consumption efficient fans.
- Includes direct expansion coil with sensors. Optional condensate water pump.
- CS-5DX-NE Plug&Play control with 5 speeds and telephone cable 7m included.
- Requires MITSUBISHI ELECTRIC VRF Interface KIT adapted for air curtain with expansion valve and programmable control, please consult.
- Ready to connect to MITSUBISHI ELECTRIC VRF outdoor heat pump unit (R410A), not included, the customer should purchase it.

Specifications

Model	Airflow m ³ /h	Power Fans 230V-50Hz kW	Current Fans 230V-50Hz A	Noise Level (5 m) dB(A)	Weight kg	Mitsubishi Electric Kit Interface VRF (*)
RDAM ECM 1500 VRF12-ME	2460	0,198	1,71	57	74	PAC-AH125M-J
RDAM ECM 2000 VRF16-ME	3280	0,264	2,28	58	95	PAC-AH125M-J
RDAM ECM 2000 VRF19-ME	3280	0,264	2,28	58	95	PAC-AH250M-J
RDAM ECM 2500 VRF21-ME	4100	0,330	2,85	59	106	PAC-AH250M-J
RDAM ECM 2500 VRF24-ME	4100	0,330	2,85	59	106	PAC-AH250M-J
RDAM ECG 1000 VRF10-ME	2190	0,225	1,95	61	55	PAC-AH125M-J
RDAM ECG 1500 VRF13-ME	2920	0,300	2,60	62	80	PAC-AH125M-J
RDAM ECG 1500 VRF15-ME	2920	0,300	2,60	62	80	PAC-AH125M-J
RDAM ECG 2000 VRF20-ME	4380	0,450	3,90	63	105	PAC-AH250M-J
RDAM ECG 2000 VRF24-ME	4380	0,450	3,90	63	105	PAC-AH250M-J
RDAM ECG 2500 VRF25-ME	5110	0,525	4,55	64	114	PAC-AH250M-J
RDAM ECG 2500 VRF29-ME	5110	0,525	4,55	64	114	PAC-AH250M-J

(*) Includes direct expansion valve.

MITSUBISHI ELECTRIC VRF compatible Outdoor Units	
Range	Series
City Multi	SY (Heat Pump)
City Multi	R2 (Heat Recovery)
Mr. Slim	Standard Inverter
Mr. Slim	Power Inverter
Mr. Slim	Zubadan
Industrial	Standard Inverter
Industrial	Power Inverter

When adverse weather conditions, the outdoor unit capacity can decrease. It is recommendable to oversize the units.



Dimensions

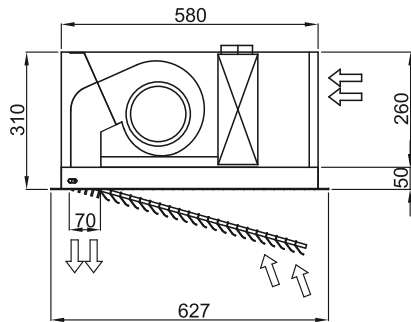
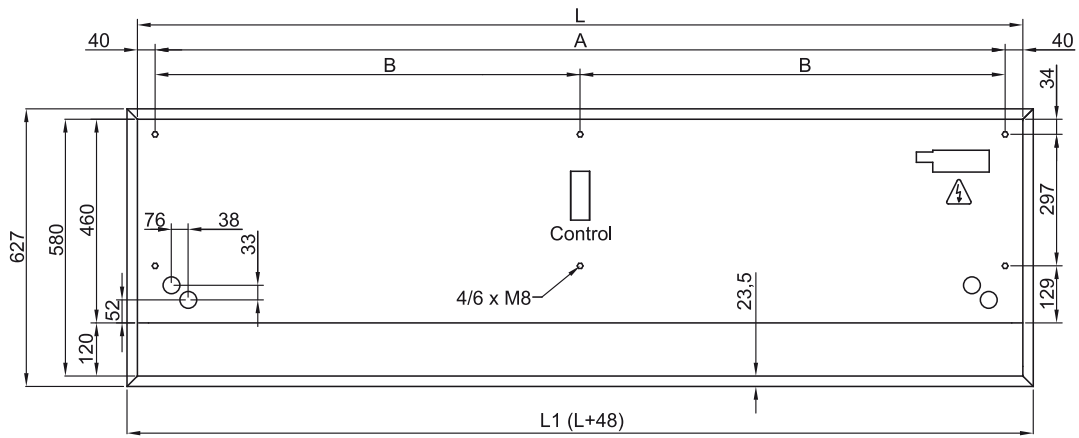

	L	L1	A	B
RDAM 1000	1000	1048	920	-
RDAM 1500	1500	1548	1420	710
RDAM 2000	2000	2048	1920	960
RDAM 2500	2500	2548	2420	1210

Finishes and details



Detail of exposed inlet grille

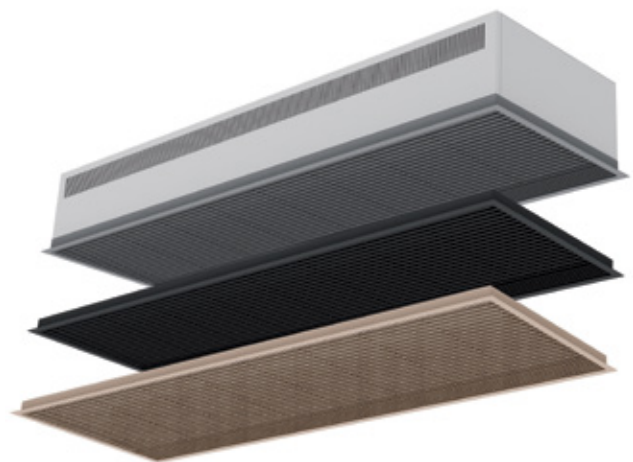

Customizable inlet grille in RAL color optionally