



Characteristics



- Energy saving heat pump air curtains: Up to 70% reduction in costs and CO₂ emissions (heating mode).
- Specially designed to be installed in all type of revolving doors. Two possible layouts, tailored dimensions: standard (on top mounting) or inverted (false ceiling mounting).
- Self-supporting casing construction made of galvanized steel plate, finished in structural epoxy-polyester painting white colour RAL9016 as standard. Other colours or stainless steel are available on request.
- Large perforated inlet grille avoiding intensive maintenance.
- Circular anodized aluminium outlet vanes, airfoil shaped.
- EC Double-inlet centrifugal fans driven by an external rotor motor and low noise level, with very low consumption efficiency fans.
- Includes direct expansion coil with sensors. Optional condensate water pump.
- CS-5DX-NE Plug&Play control with 5 speeds and telephone cable 7m included.
- Requires DX Interface KIT adapted for air curtain and programmable control, please consult.
- Ready to connect to MIDEA Inverter outdoor heat pump unit (R410A) with expansion valve, not included, the customer should purchase it.

Specifications

Model	Airflow m ³ /h	Outdoor Unit (*)		Power Fans	Current Fans	Noise Level	Weight
		230Vx1	400Vx3	230V-50Hz kW	230V-50Hz A	(5 m) dB(A)	
ROTO ECG 1000 DX10-MD	2190	MOD30U-36HFN1-QRD0	MOD30U-36HFN1-RRD0	0,225	1,95	61	-
ROTO ECG 1500 DX15-MD	2920	MOE30U-48HFN1-QRD0	MOE30U-48HFN1-RRD0	0,300	2,60	62	-
ROTO ECG 2000 DX18-MD	4380	-	MOE30U-55HFN1-RRD0	0,450	3,90	63	-
ROTO ECG 2000 DX22/2-MD	4380	2x MOD30U-36HFN1-QRD0	2x MOD30U-36HFN1-RRD0	0,450	3,90	63	-
ROTO ECG 2500 DX29/2-MD	5110	2x MOE30U-48HFN1-QRD0	2x MOE30U-48HFN1-RRD0	0,525	4,55	64	-

22/2 Double circuit and two outdoor units of 11kW. 29/2 Double circuit and two outdoor units of 16kW.

(*) Includes direct expansion valve.

MIDEA Inverter Outdoor Units	Heating Capacity	Heating Power	SCOP or COP (*)	Cooling Capacity	Cooling Power	SEER or EER (*)	Power Supply	Pipes Gas Liquid	Pipes Maximum Length	Pipes Maximum Height
	kW	kW	W/W	kW	kW	W/W		inch	m	m
MOD30U-36HFN1-QRD0	11,1	2,9	3,82	10,5	3,95	2,65	230Vx1	5/8 3/8	65	30
MOD30U-36HFN1-RRD0	11,1	2,9	3,82	10,5	3,95	2,65	400Vx3	5/8 3/8	65	30
MOE30U-48HFN1-QRD0	16,1	4,4	3,65	14,1	5,10	2,76	230Vx1	5/8 3/8	65	30
MOE30U-48HFN1-RRD0	16,1	4,4	3,65	14,1	5,10	2,76	400Vx3	5/8 3/8	65	30
MOE30U-55HFN1-RRD0	17,6	5,5	3,20	16,1	6,30	2,55	400Vx3	5/8 3/8	65	30

Energy efficiency: SCOP/SEER seasonal ≤12kW, COP/EER >12kW.

Outdoor unit capacities depending on standard conditions: heating 20°CDB indoor / 7°CDB and 6°CWB outdoor, cooling 27°CDB and 19°CWB indoor / 35°CDB outdoor.

When adverse weather conditions, the outdoor unit capacity can decrease. It is recommendable to oversize the units.



Layouts and dimensions

Rotowind air curtains are tailor-made for any kind of revolving door according to the following layouts:

Standard: On top mounting

Inverted: False ceiling mounting

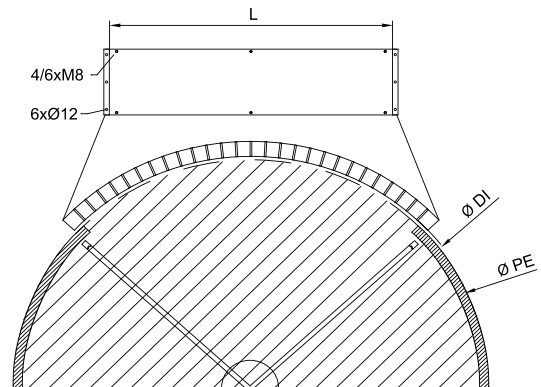
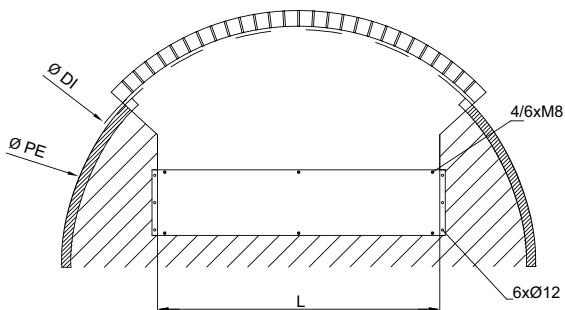
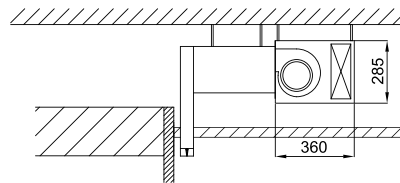
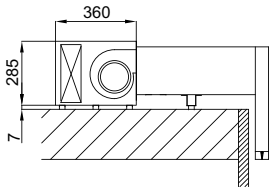
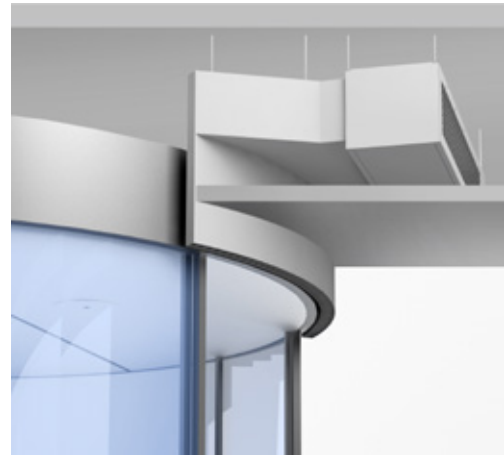

Fixation system

Optional decorative front cover



Fixed onto the door

Hanging from the ceiling

- RAL 9016 (standard), optional:
- Colour from RAL palette
 - Stainless steel AISI 304